



INSULATION SET KLINGERSIL C-4430



Insulation sets are used to limit corrosion in pipeline systems. Where dissimilar metals are present, the sets remove the possibility of the system acting as a galvanic cell and reduce the risk of galvanic corrosion of the pipework

Insulation sets are also used to isolate cathodically protected piping systems where they prevent the flow of electro-static charge.

Each flange insulation set comprises one central gasket, one insulation sleeve per bolt and two insulating and two plated steel washers per bolt. The sets are individually packed and clearly labelled with the flange rating, size, type and material combination.

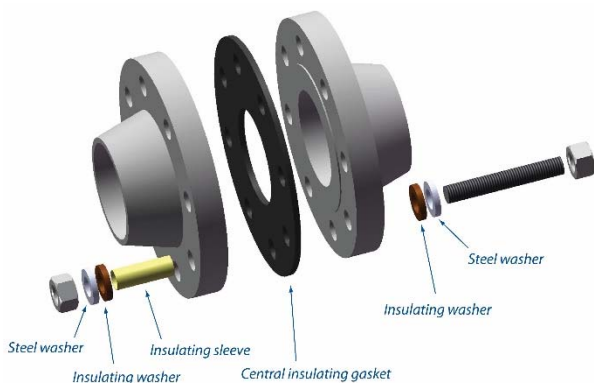

GENERAL PROPERTIES FOR C-4430

- » Excellent creep resistance
- » Good steam resistance
- » Resistant to oils, fuels, hydrocarbons etc.
- » WRAS approved for use in hot and cold potable water
- » Fire-safe
- » 3xA anti-stick finish on both sides

TESTS AND CERTIFICATIONS FOR C-4430

- » BS 7531 Grade X
- » Firesafe ISO EN 10497
- » Firesafe ISO 19921
- » WRAS Approval
- » TA-Luft
- » DIN-DVGW
- » DIN-DVGW W 270
- » DVGW VP 401
- » Elastomer Guideline
- » BAM Tested
- » Germanischer Lloyd

KLINGERSIL C-4430

Optimised combination of synthetic fibres and glass-fibre bound with NBR. Premium quality jointing with high temperature resistance in steam and water as well as excellent resistance to oils and hydrocarbons.

Property	Units	C-4430 Gasket
Compressibility	%	9
Recovery	%	50
Stress Relaxation (DIN 52913, 50MPa, 16h, 300°C)	MPa	35
Dielectric strength	kV/mm	21
Water Absorption	%	10.6
Maximum Temperature	°C	250

INSULATION SLEEVES

Property	Units	Mylar * Sleeves	Glass reinforced epoxy resin	Nomex	HT Sleeves
Dielectric strength	kV/mm	157	12.2	15.75	22
Water Absorption	%	0.8	0.04	0.8	-
Maximum Temperature	°C	180	150	230	650

*Denotes standard insulation sleeve material

INSULATION WASHERS

Property	Units	G10 *	G11	HCS
Compressive strength	MPa	475	345	>500
Dielectric strength	kV/mm	31.5	19.7	15.75
Water Absorption	%	0.05	0.085	-
Maximum Temperature	°C	150	200	250

*Denotes standard insulation washer material

HEAD OFFICE
 KLINGER Ltd
 Wharfedale Road
 Euroway Trading Estate
 Bradford BD4 6SG

Tel: 01274 688 222
 Fax: 01274 688 549
 www.klinger.co.uk
 enquiries@klingeruk.co.uk



FM 602916 FM 10571 OHS 570166 EMS 570165

KLINGER RUNCORN
 Tel: 01928 577 030
 Fax: 01928 575 233
KLINGER SOUTHAMPTON
 Tel: 02380 611 855
 Fax: 02380 610 360
KLINGER ABERDEEN
 Tel: 01224 772 962
 Fax: 01224 772 953

KLINGER IMMINGHAM
 Tel: 01469 575 289
 Fax: 08449 676 779
KLINGER MIDDLESBROUGH
 Tel: 01642 220 289
 Fax: 01642 220 290
KLINGER GRANGEMOUTH
 Tel: 01324 472 231
 Fax: 01324 482 111